

MEGAMAX & MORE

Low beds - High performance





FAYMONVILLE

TRAILERS TO THE **MAX**



With an **experience of over 50 years**, Faymonville is one of the biggest manufacturers of semi-trailers for special and heavy haulage.

Faymonville provides their customers with optimal solutions and systems for any transport need outside the usual norms.

Quality, flexibility, productivity, creativity and **service** are the company's keywords. The range of products and services is constantly enlarged in tight collaboration with our customers.



The **high level of innovation** and the excellent manufacturing quality of the products are secured by optimized production processes and own modern production plants in Büllingen (Belgium), Lentzweiler (Luxembourg) and Goleniow (Poland). A service station has been opened in Noginsk (near Moscow, Russia).



MEGAMAX



The Mega**MAX** low bed semi-trailer is the optimum solution when transporting higher goods, industrial parts or machines. The low loading height can prove to be the deciding factor in such cases. The Mega**MAX** is also the best option for maximum manoeuvrability and operation flexibility.

The Mega**MAX**, a tried and tested product series with a complete range of specific options to enable customised vehicle designs and combinations.

Main characteristics

- Lower loading height
- Especially suitable for heavy duty and special transports
- 1 to 7 axles
- High payload
- Length-optimized loading platform

Technological aspects of the MegaMAX

1. Goosenecks

■ *Central beam neck (ZT)*

If especially heavy loads for construction and industry sites need to be transported, a central beam in the gooseneck is selected for the low bed semi-trailer. This enables a simple and light coupling process and thereby smooth loading from the front. Such a central beam neck is indispensable when adding a 2 or 3-axle dolly to the low bed semi-trailer.

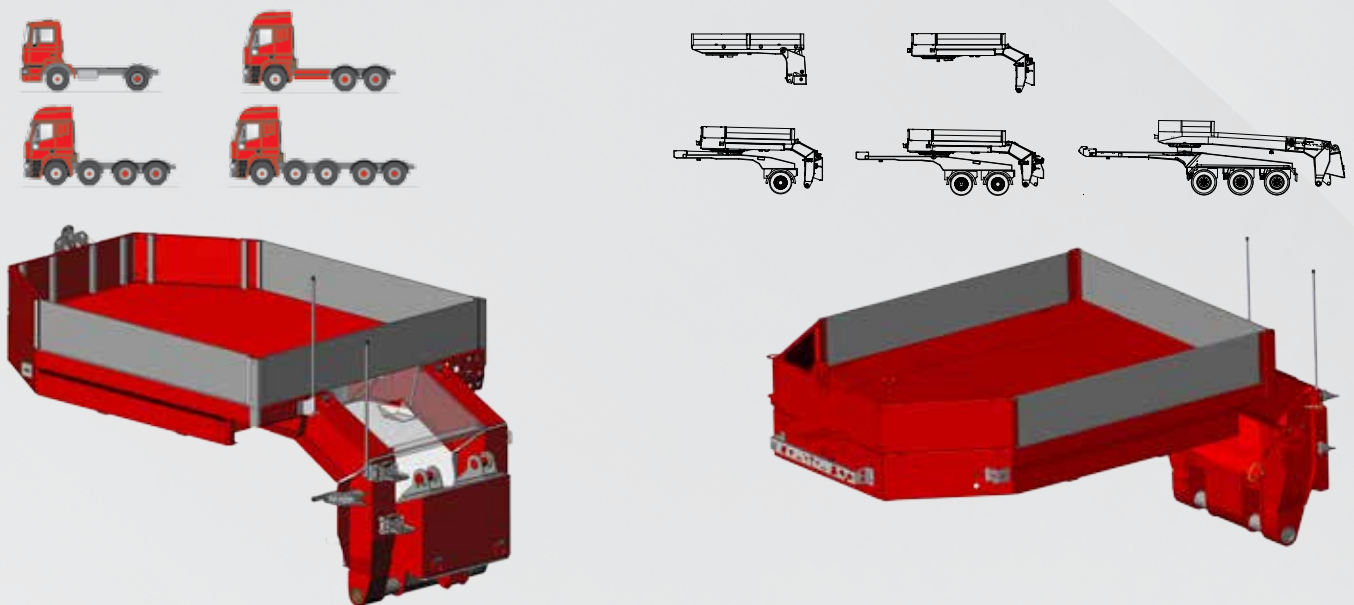

■ *Outer beam neck (AT)*

This type of gooseneck also makes it possible to use a 1-axle dolly, which is especially applicable when transporting industrial goods.

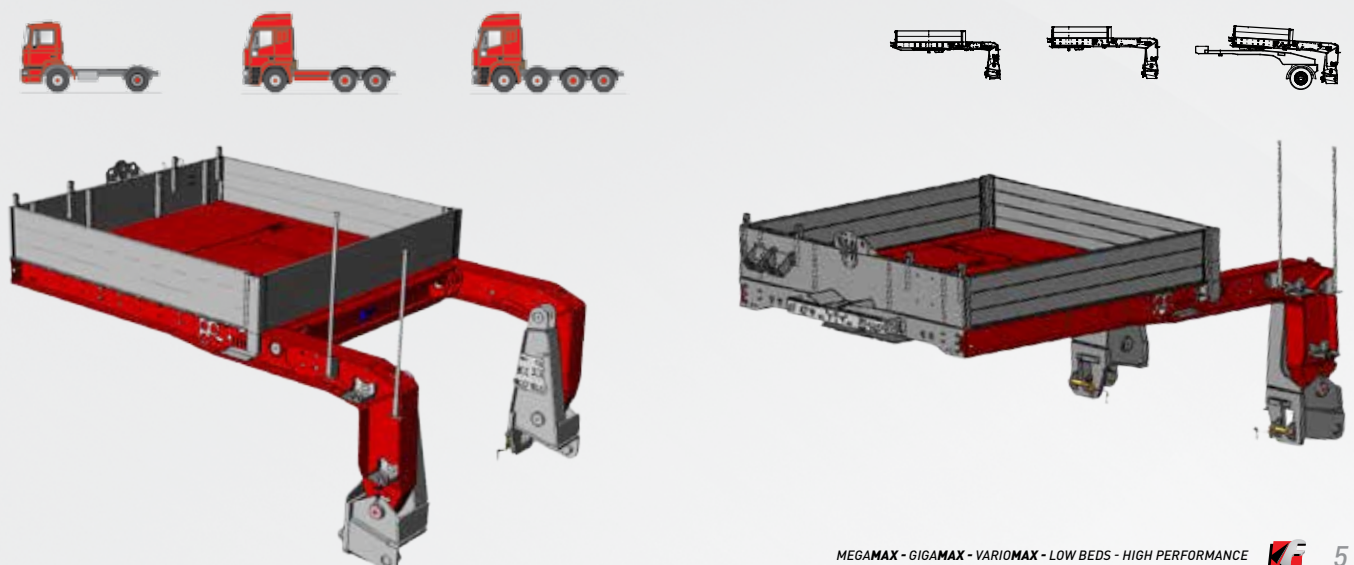

2. Front loading



3. Accessories

■ *Outriggers*

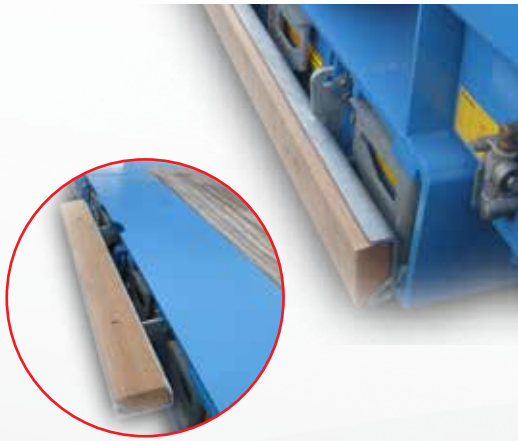

Outriggers



Center spine
with removable mattresses



■ **Accessories**



Single ramp for front loading



Double ramp for front loading



Detachable gooseneck with outer beams



Removable ramps for outer beam-gooseneck system



Hydraulic quick coupling

■ **Wheel recess & excavator trough**



Turnable wheel-recess for center spine



Wheel recess on the gooseneck



Excavator trough

■ **Boat accessories**



Widenable boat-support

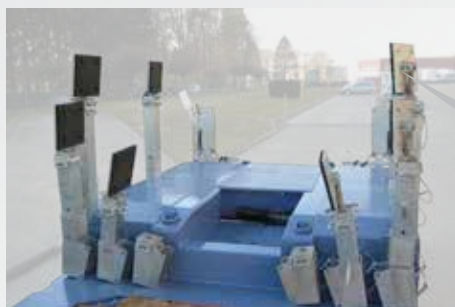

Boat-support



GIGAMAX



The low bed semi-trailer with a pendle axle integrated behind the gooseneck

The Giga**MAX** is a low bed semi-trailer designed for **heavy duty** and **special transports**.

Based on 3 to 6 axles, the Giga**MAX** can cope with a **high technical payload** while featuring a **compact design**. The 1-2 axles integrated behind the gooseneck contribute to the further **reduction of the overall length** and weight of the combination.

Main characteristics

- Length and weight-optimized construction
- Maximum manoeuvrability and efficiency during loading and transport
- Also available in a lightweight version
- Removable gooseneck

Technological aspects of the GigaMAX

4. Goosenecks Front bogies

The *GigaMAX* is defined by gooseneck with integrated Pendle-axle bogie. Thereby, it creates an extremely compact loading platform and the integrated Pendle-axle increases the payload in the front vehicle section. The central hook adapter allows for easy (un-)coupling of the lowbed and loading from the front.

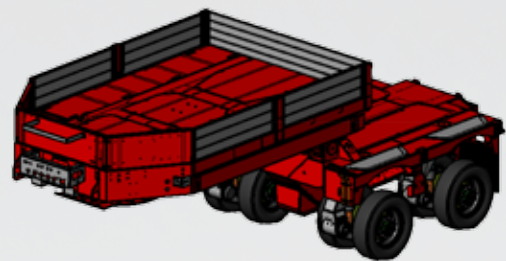
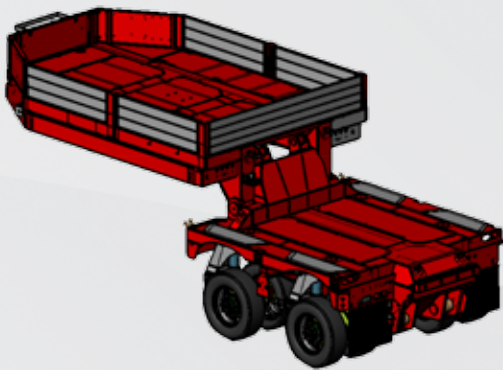
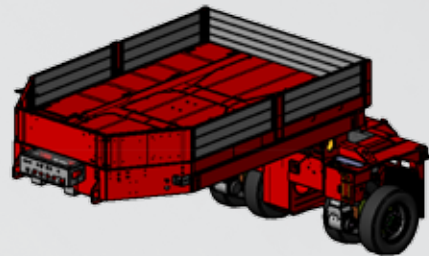
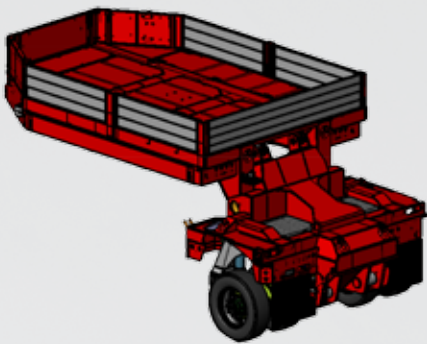

VARIOMAX



The low bed semi-trailer with a removable pendle axle bogie between the gooseneck and the low bed.

The Vario**MAX** is a particularly adaptable and versatile *series of semi-trailers*, consisting of a front and rear bogie, based on 3 to 9 axles.

The low loading height and high payload of the Vario**MAX** semi-trailer are the economic and flexible solution for numerous different tasks in *heavy duty* or *special transport*.

Main characteristics

- Low loading height
- High payload
- Also available in a lightweight version
- Removable gooseneck

Technological aspects of the VarioMAX

5. Goosenecks Front bogies

The VarioMAX allows for 1-3 axle bogies to be connected directly behind the gooseneck. Thanks to its central beam construction, the gooseneck can easily be (un-)coupled and enables safe loading from the front. The front Pendle-axle bogies can be disconnected from the gooseneck if required and can be transported on the lowbed when driving empty to minimize the total length.

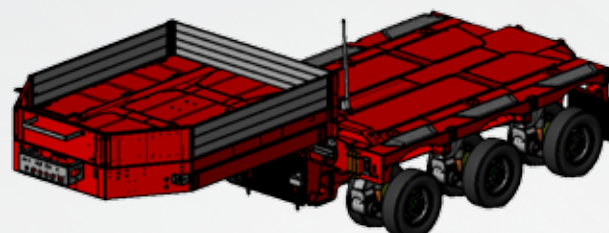
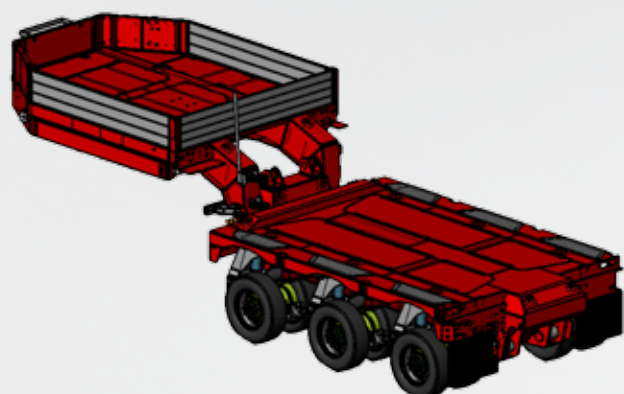
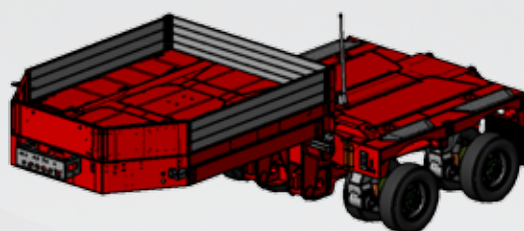
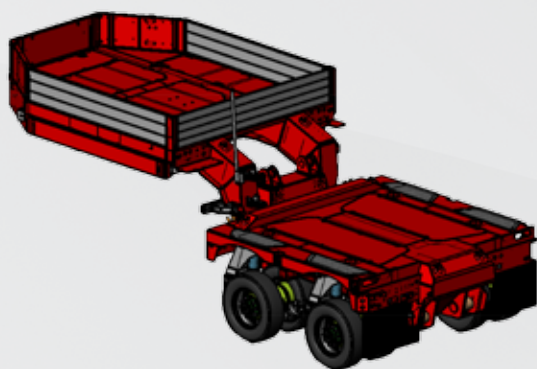
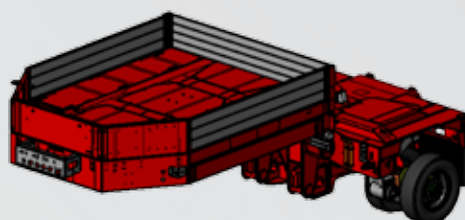
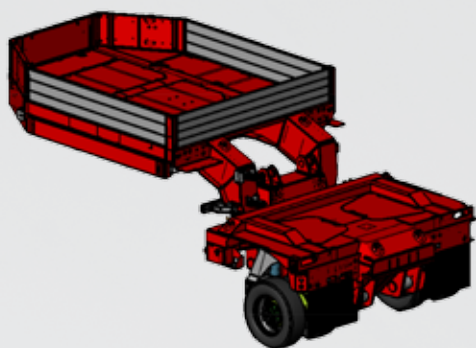

6. Low beds

Low beds are available in many different shapes and payload categories. The customer can either select from a wide range of standardised beds or a custom-made loading platform to suit the individual requirements.

■ *KBV: Hydraulic widenable vesseldeck*

The vesseldeck offers maximum flexibility with an extendable loading floor by using hydraulic widening. These low beds are available as single or double telescopic units. The high load-carrying capacity creates the ideal solution for transporting industrial vessels, transformers or boats.

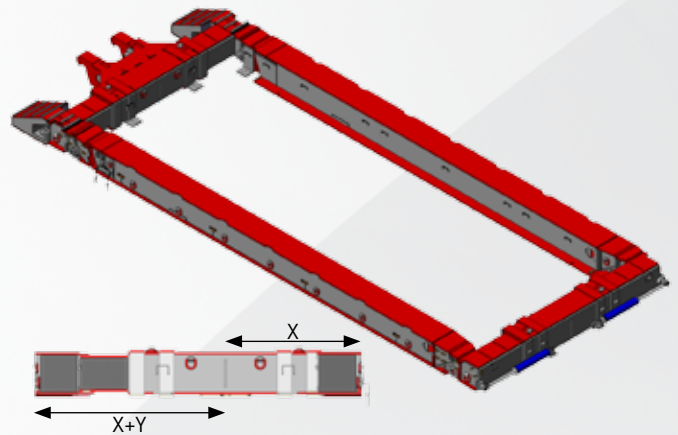

■ *KBX: Flat vesseldeck*

The extremely flat version of the vesseldeck for implementing a very low loading height. These can be utilised for transporting high industrial goods, precast concrete parts or room modules. This flatbed frame can be supplied in a single or double telescopic version.

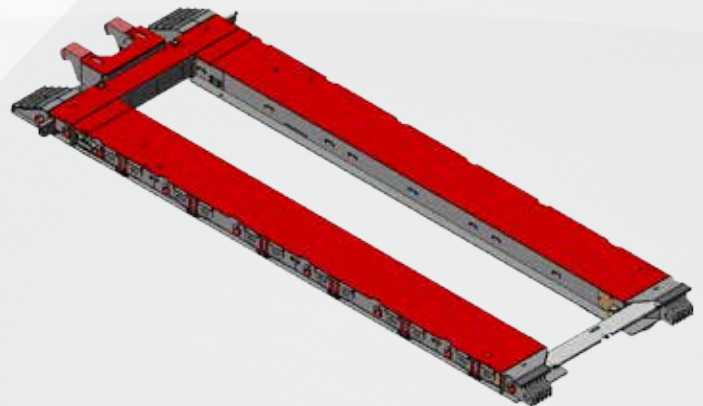

■ *ATX: Flat outer beams*

The low construction height guarantees sufficient loading height under extreme loads. Standard version: Fixed built-in base floor.

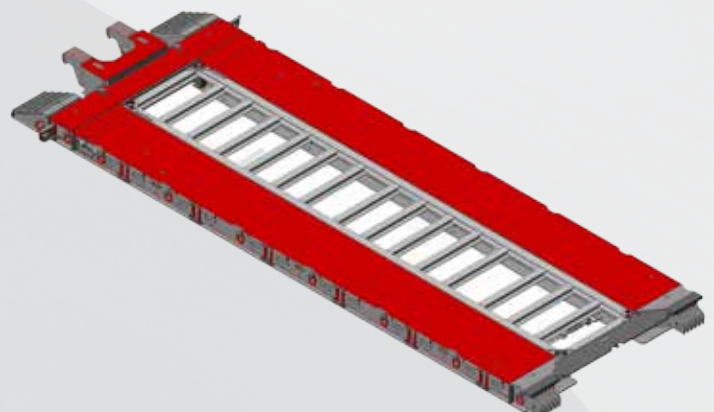



■ *BB: Excavator deck*

Heavy machinery can be transported by utilising an excavator deck with minimum ground clearance (hanging). Such low beds can also be telescopic, which makes them versatile for many applications. The reversible outriggers enable loading on 3 levels.

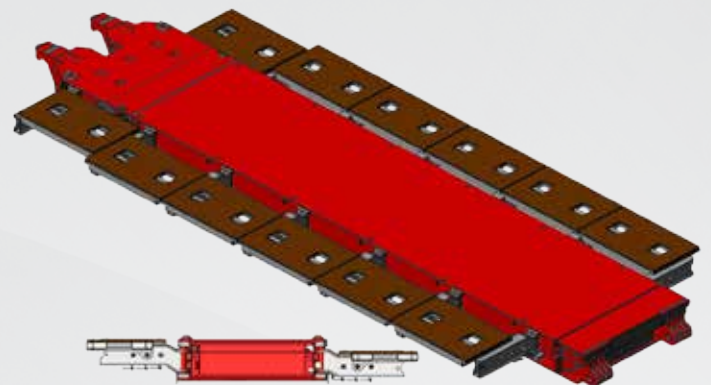

■ *ATV: Widenable outer beams*

The hydraulic widening enables this variation to be adjusted to suit the width for the loading platform. Full loading-capacity with maximum widening is therefore guaranteed. A simple extension is also possible with this low bed. Ideal for transporting heavy, wide construction machines.

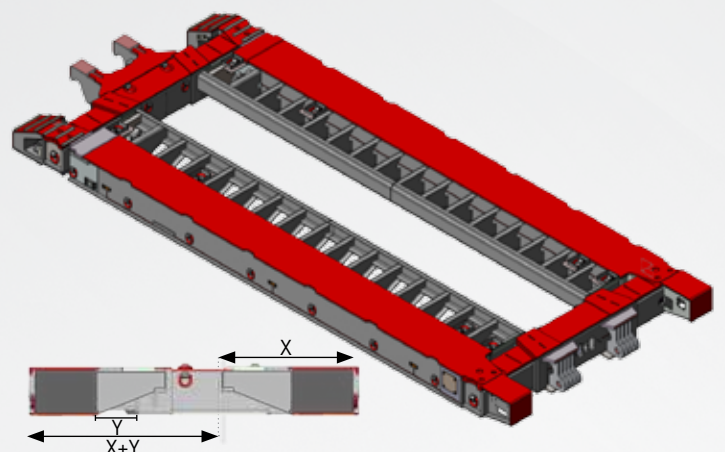



7. Bogies

■ *Stub axle steering (Z)*

Depending on which application area and loading weight is required, the pneumatic or the hydraulic version of the stub axle can be chosen. The steering angle between 42° and 45° is useful for optimum manoeuvrability.

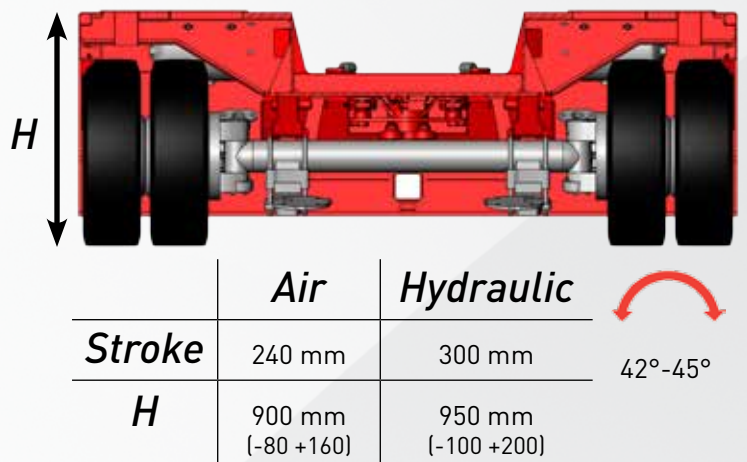

■ *Hydraulic swing axle (PA)*

Swing axles are especially suited for applications on particularly difficult routes and under hard topographic conditions. A maximum total lift of impressive 600 mm as well as the maximum steering angle of over 60° characterize this type of axle. The swing movement enables the optimum axle-load compensation between the individual axles on uneven surfaces and differing ground clearances.

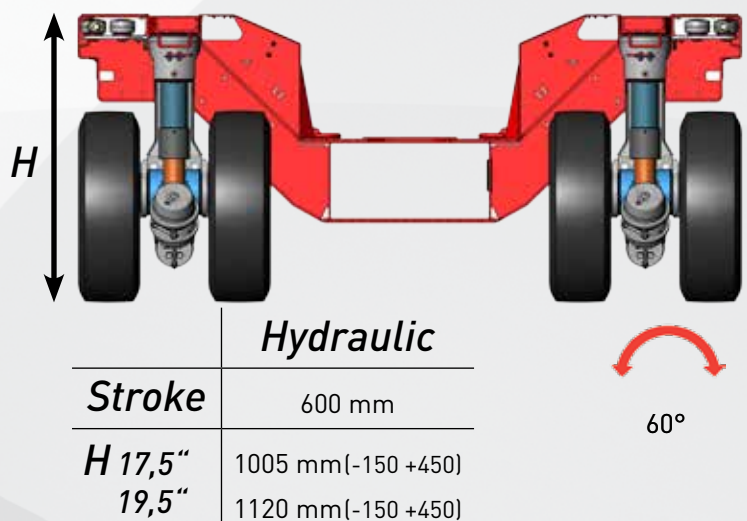

■ *Twin Axle II - Independent suspension (TAII)*

The independent suspension „Twin Axle II“ enables an increase of the payload to 12 tons per axle in various countries (e.g. Germany). This type of axle provides a larger lift of 310 mm (-70 mm / +245 mm), with the benefit of a minimum loading height (780 mm) over the axles. The independent suspension also achieves a maximum steering angle of 55°.

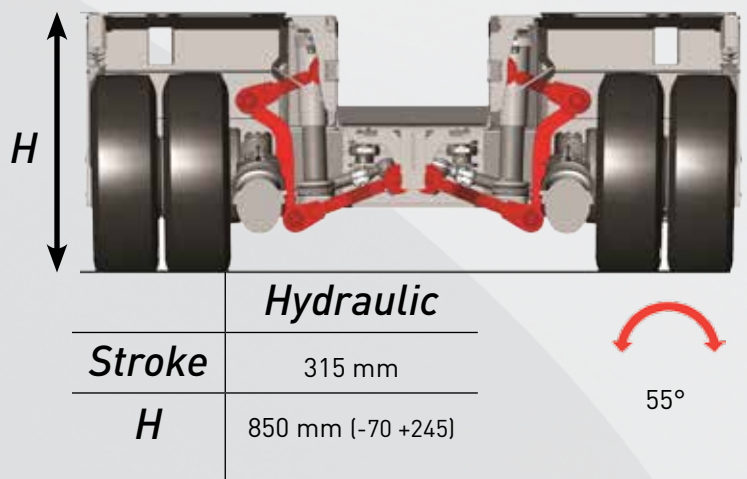

8. Application areas for the MegaMAX

- Bulky goods and heavy loads
- Construction machines (excavation and road construction, recycling, road grooving machine transport, crushing equipment, screening equipment)
- Wind power plants (tower segments, generators, rotor or turbine blades, hybrid towers)
- Forestry machines (harvester, skidder, forwarder)
- Farming machines (combine harvesters, tractors, farming tractors, beet harvesters, silage wagons, liquid manure tanks)
- Industrial parts (crane-loaded goods, vessels, ring transport)
- Yacht transport
- Precast concrete parts



The MegaMAX in action



9. Application areas for the GigaMAX

- Heavy construction machines (excavation and road construction, recycling, road planning machines, crushing equipment, screening equipment)
- Wind power plants (tower segments, generators, rotor or turbine blades, hybrid towers)
- Structural elements (steel and concrete elements)
- Industrial parts (transformers, crane-loaded goods, ring transport)
- Crane systems (cranes, crane weights, crane components)
- Conveying and crushing systems (demolition and recycling industry)
- Track-guided vehicles (trams, locomotives, wagons)
- Boats (yachts)
- Precast concrete parts
- Bulky goods and heavy loads



The GigaMAX in action



10. Application areas for the VarioMAX

- Heavy construction machines (excavation and road construction, recycling, road planning machines, crushing equipment, screening equipment)
- Wind power plants (tower segments, generators, rotor or turbine blades, hybrid towers)
- Structural elements (steel and concrete elements)
- Industrial parts (transformers, crane-loaded goods, ring transport)
- Crane systems (cranes, crane weights, crane components)
- Conveying and crushing systems (demolition and recycling industry)
- Track-guided vehicles (trams, locomotives, wagons)
- Boats (yachts)
- Precast concrete parts
- Bulky goods and heavy loads



The VarioMAX in action



TOWERMAX

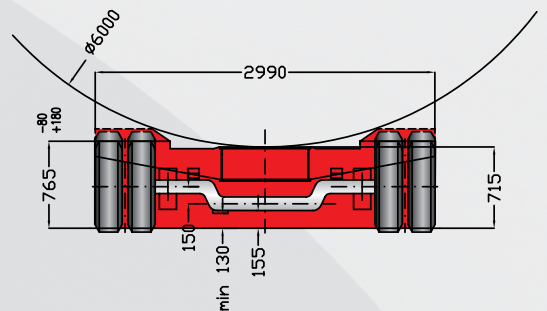
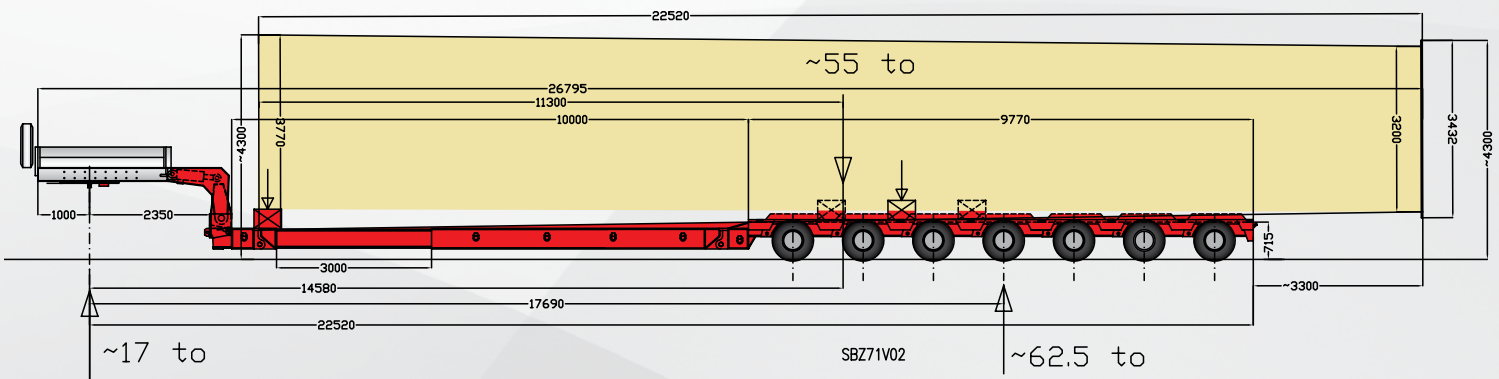

MAXPROTECT+

Weather conditions and environmental influences as well as corrosion and stone chips are the biggest enemies of a steel structure. For the long-term surface protection of semi-trailers, FAYMONVILLE relies on **MAXPROTECT+**, a fully co-ordinated and meticulously optimized surface treatment system.

MAXPROTECT+ is by far the best concept currently available in the industry. That is why it sets the benchmark in the field of surface protection. Our **MAXPROTECT+** treatment offers a long-life surface protection.

All stages and processes included in **MAXPROTECT+** – from the painting to the metallisation, including shot- and sandblasting – are carried out, developed and tested 'in-house'.

This optimum surface treatment additionally increases the quality and longevity of our products.

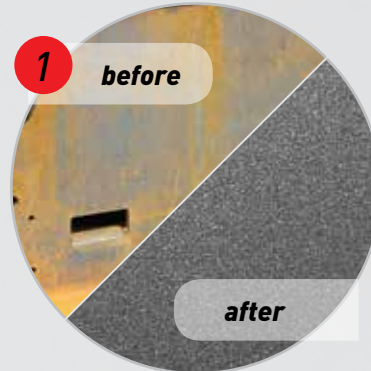

- Composition of the surface refinement**
- 1 Machine blasting**
Airless blast cleaning with metallic shot.
 - 2 Manual blasting**
Manual cleaning and refinement of the material surface with mineral blasting agents.
 - 3 Spray galvanising**
Application of a zinc/aluminium layer for corrosion and adhesion protection. Partial metallisation especially for strongly stressed surfaces.
 - 4 Joint sealing**
Prevents the spread of rust in the gap and underneath the paintwork.
 - 5 Priming**
2-component zinc epoxy with 81% zinc content and additional active corrosion protection.
 - 6 Top coat**
Final coating with 2-component DTM.
 - 7 Sealing**
Prevents corrosion in corners and hollow spaces.
 - 8 Optional: Seawater-resistant complete preservation**



FAYMONVILLE DISTRIBUTION AG

8, Duarrefstrooss | L-9990 WEISWAMPACH
T: +352 / 26 90 04 155 | F: +352 / 26 90 04 425
sales@faymonville.com

www.faymonville.com

